

# Meeting Agenda

## Ward 2 Neighborhood Planning Assembly (NPA)

Nov 13th, 2025 | 6:30-8:30pm | All are welcome



### Join in person:

ONE Community Center, 20 Allen Street

### Join remotely:

<https://zoom.us/j/93179389982>

### O.N.E. Community Dinner

5:30-6:30pm | Free | Donations welcome

**Laotian Menu with Guest Chef Phet Keomanyvanh of Moo Noit Market**

**Music:** Brian Perkins

**Facilitator:** Nora Aronds (she/her)

**Notetaker:** Kason Hudman

### 6:30 pm Introduction

5 min Review and adopt/approve the agenda and previous minutes; introductions as time allows.

### 6:35 pm Public Forum (2 minutes max per person)

10 min Please state your full name, pronouns, street, and ward, and follow the NPA ground rules.

### 6:45 pm Community Support for Apartheid-Free Pledge Request

25 min *Duncan Kreps, Jill Clark-Gollub, Paul Fleckenstein - VT Coalition for Palestinian Liberation*

Learn more about the open letter to City Council to allow voter decision on Apartheid-Free pledge.

### 7:10 pm Migrant Justice Overview & Updates

25 min *Rachel Elliott - Communications & Development Coordinator, Migrant Justice*

Hear about what is currently happening in the community and how you can help.

### 7:35 pm Updates from Community Resource Center (CRC)

25 min *Brenna Bedard - CRC Outreach Coordinator, Champlain Valley Office of Economic Opportunity*

Learn about current goings ons at the CRC and how best to get or provide support with them.

### 8:00 pm Overview of Two Development Projects in the ONE:

#### 126 North Ave

15 min each *Michael Chaucer - Haven Architecture LLC*

#### 134–141 Archibald Street

*Michael Alvanos - JRMA Design Studio*

### 8:30 pm Door prize drawing + Adjourn!

Our next meeting is Thursday, Dec. 11!

---

Scan the QR code ([or click here](#)) to: [Email us](#) • Go to [our website](#) • Watch meeting recordings on [CCTV's website](#) • Connect with us on [Instagram](#) • Request a time slot with the [request form](#) • Get to all links related to this meeting



# Appendix to the Agenda

## Ward 2 NPA Steering Committee

To contact the entire Ward 2 NPA Steering Committee, email [ward2npa@googlegroups.com](mailto:ward2npa@googlegroups.com)

Name	Email	Joined	Term expiration
Lauren Ebersol	lebersol27@gmail.com	2023	2027
Kason Hudson	kasonhudman@gmail.com	2024	2028
Charlie Giannoni	charliecpg@gmail.com	2024	2028
Marc Stannard	Marc.Stannard@outlook.com	2024	2028
Nora Aronds	noraaronds@yahoo.com	2025	2029
Grace Sherwood	Gsherwood703@gmail.com	2025	2029

## NPA Guiding Principles

- Operate through democratic principles and democratic procedures.
- Provide a safe and welcoming forum where residents can actively share their voices about issues that matter to them, and where they can learn from the voices of others.
- Cultivate involvement by a diverse spectrum of community members through active outreach and through eliminating barriers to participation.
- Operate in a manner that models respectful, inclusive, culturally, and economically aware practices.
- Be a fun, creative, and vital organization that provides value and benefit through the multitude of perspectives shared by those who participate.

## Ward 2 NPA Ground Rules

- Meetings should have **clearly defined agenda and roles**.
- **Honor time limits:** A best effort must be made to start on time, follow the agenda, and finish on time.
- **Listen to others:** Make efforts to be an open-minded member of the group.
- **Respect the agenda and the process:** Try to remain focused on the issue at hand.
- **Share your opinion respectfully:** Speak out, but not over, others' comments.
- **Treat people how you would like to be treated:** Be respectful of everyone, including guests.

## Elected officials representing Ward 2

### Mayor

Mayor Emma Mulvaney-Stanak	Progressive	mayor@BurlingtonVT.gov
----------------------------	-------------	------------------------

### City Councilors

Central District (Wards 2 & 3)	Melo Grant	Progressive	megrant@burlingtonvt.gov	802-310-0962
Ward 2	Gene Bergman	Progressive	gbergman@burlingtonvt.gov	802-598-3602

### School Board Members

Central District (Wards 2 & 3)	Jean Waltz	jwaltz@bsdvt.org	802-355-7856
Ward 2	Polly Vanderputten	pvanderputten@bsdvt.org	802-578-8653

### Vermont State House Representatives

Chittenden-15	Troy Headrick	Independent	theadrick@leg.state.vt.us	(802) 828-2228
Chittenden-15	Brian Cina	Progressive/Democrat	bcina@leg.state.vt.us	(802) 828-2228
Chittenden-16	Kate Logan	Progressive/Democrat	klogan@leg.state.vt.us	(802) 828-2228
Chittenden-16	Jill Krowinski	Democrat	jkrowinski@leg.state.vt.us	(802) 828-2228
Chittenden-17	Abigail Duke	Democrat	aduke@leg.state.vt.us	(802) 828-2228

### Vermont State Senators

Chittenden-Central	Tanya Vyhovsky	Progressive/Democrat	tvyhovsky@leg.state.vt.us	(802) 828-2228
Chittenden-Central	Martine Gulick	Democrat	mgulick@leg.state.vt.us	(802) 828-2228
Chittenden-Central	Philip Baruth	Democrat/Progressive	pbaruth@leg.state.vt.us	(802) 503-5266



# APARTHEID - FREE

**Burlington, VT**

NPA Meeting Tour

# AGENDA



**Israeli  
Apartheid and  
the Genocide**



**Local  
Campaign**



**Next Steps**



**Open  
Discussion  
and Q&A**

# THE CRIME OF **APARTHEID**

The 1998 Rome Statute to the International Criminal Court and 1973 International Convention on the Suppression and Punishment of the Crime of Apartheid define apartheid as a **crime against humanity** consisting of three main elements:

- 1 AN INTENT TO MAINTAIN DOMINATION**  
BY ONE RACIAL GROUP OVER ANOTHER
- 2 A CONTEXT OF SYSTEMATIC OPPRESSION**  
BY ONE RACIAL GROUP OVER ANOTHER
- 3 INHUMANE ACTS**

# Israeli apartheid: 4 strategies

## **Dispossession**

Decades of discriminatory land and property seizures, home demolitions, and forced evictions

## **Segregation**

A system of laws and policies that keep Palestinians restricted to enclaves, subject to several measures that control their lives, and segregated from Jewish Israelis

## **Deprivation**

The deliberate impoverishment of Palestinians. For example, keeping them at a great disadvantage in comparison to Jewish Israelis

## **Fragmentation**

Keeping Palestinians separated from each other into distinct territorial, legal and administrative domains

Source: Amnesty International



# Israeli apartheid: According to whom?

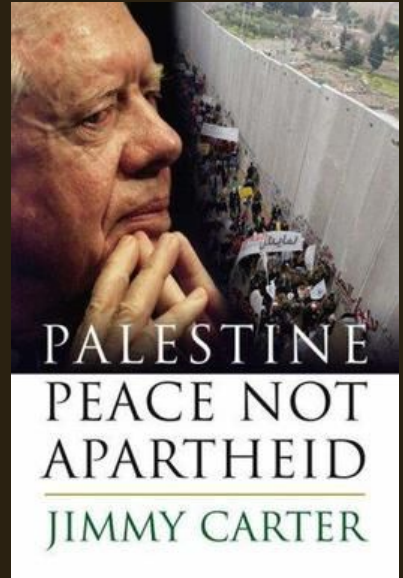

Advisory opinion on July 19, 2024 found Israel **responsible** for committing apartheid.

# Israeli apartheid: According to whom?

- The Knesset, the legislature of Israel, in 2018 codified “Israel as the Nation-State of the Jewish People”
- The legislation passed with a significant majority, and led to human rights groups defining Israel as an apartheid state

**“Israel is the historical homeland of the Jewish people... The right of national self-determination in the State of Israel is unique to the Jewish people” - 2018**

# PALESTINE SHRINKING EXPANDING ISRAEL

1918



UNDER OTTOMAN RULE, ZIONIST ORGANISATIONS INCLUDING THE JEWISH NATIONAL FUND BEGIN TO MAKE **LAND PURCHASES THROUGHOUT PALESTINE** FOR JEWISH SETTLEMENT.

1947



PRIVATISATION OF LAND UNDER THE BRITISH MANDATE **ACCELERATES ITS TRANSFER AND SALE TO ZIONIST ORGANISATIONS,** AND THE DISPLACEMENT OF PALESTINIAN INHABITANTS.

1960



FOLLOWING THE **FORCED DISPLACEMENT (NAKBA) OF OVER 750,000 PALESTINIANS** IN 1948, THE NEW STATE OF ISRAEL ENACTS LAWS TO **CONFISCATE THE VAST MAJORITY** OF PALESTINIAN LANDS.

2017



SINCE OCCUPYING THE WEST BANK AND GAZA IN 1967, ISRAEL HAS UNILATERALLY DECLARED **TENS OF THOUSANDS OF HECTARES** OF SO CALLED 'STATE LAND' FOR **ISRAELI SETTLEMENTS.**

#### SOURCES

Text based on:

BAKIL, 2000. *Land Ownership in Palestine/Israel 1920-2000*.  
BAKIL, 2010. *Driving Land, Population Transfer And The Hermit Prolet In The Naqab*.  
B'Tselem, 2010. *By Hook And By Crook: Israeli Settlement Policy In The West Bank*.

Maps adapted from:  
HARAVI-SHARON, 2010. *Atlas of the Conflict: Israel-Palestine*.  
B'Tselem, 2014. *Map of the West Bank, Settlements and the Separation Barrier*.

■ Palestinian Land  
■ Zionist Settlements

VISUALIZING PALESTINE

WWW.VISUALIZINGPALESTINE.ORG. MAY 2015.  
SHARE AND DISTRIBUTE FREELY. CREATIVE COMMONS BY-NC-ND 3.0 LICENSE.

@visualizingpal  
fb.com/visualizingpalestine





# Israeli apartheid: Who's paying for it?

In Burlington, Vermont, \$2,959,782 to Israel's weapons could instead fund one of the following:

 **1,855** Households with one month's free rent

 **6,227** Families with one month's free groceries

 **1,029** Children's free or low-cost healthcare for one year

 **32** Elementary school teachers' salaries for one year

 **8,426** Households with solar electricity produced for a year

 **78** Students with their loan debt cancelled

In Vermont, \$27,647,196 to Israel's weapons could instead fund one of the following:

 **17,333** Households with one month's free rent

 **58,174** Families with one month's free groceries

 **9,619** Children's free or low-cost healthcare for one year

 **301** Elementary school teachers' salaries for one year

 **78,710** Households with solar electricity produced for a year

 **731** Students with their loan debt cancelled



# Local Campaign



# Who are we?

The **Vermont Coalition for Palestinian Liberation** is a collaboration of several Vermont organizations and hundreds of Vermont residents volunteering their time and energy to work for a **free Palestine**.



# Our Vermont Context

## Palestine is a local issue!!!

\$27.6 million Vermont taxpayer dollars sent to Israel in 2024

3 Palestinian students were shot in Burlington in 2023, showing the violence is not contained overseas

The Boomerang Comes Back, apartheid, hate, and violence spread across the world

Vermonters have a long history of acknowledging our interconnectedness and challenging oppression around the world. In fact, **Apartheid South Africa** ended 30 years ago because of **global solidarity of ordinary people of conscience, including many Vermonters and their communities.**



# What is the Apartheid-Free Community Pledge?

- Initiated by the American Friends Service Committee in 2022
- Based on the global movement to end South African apartheid
- 880 groups endorsed worldwide



Quaker action for a just world

JOIN THE  
**APARTHEID FREE**  
COMMUNITY MOVEMENT!

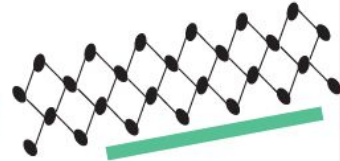

## THE PLEDGE:

### WE AFFIRM

our commitment to freedom, justice, and equality for the Palestinian people and all people;

### WE OPPOSE

all forms of racism, bigotry, discrimination, and oppression; and

### WE DECLARE

ourselves an Apartheid-free community and to that end,

### WE PLEDGE

to join others in working to end all support to Israel's Apartheid regime, settler colonialism, and military occupation.

# AFC in Vermont

- **50+** VT businesses, organizations, faith groups have endorsed AFC
- **9 Vermont towns** put AFC on the ballot in 2024
- **Winooski, Brattleboro, Newfane, Thetford, and Plainfield** all voted to adopt the AFC pledge
- **Currently there are ballot campaigns happening all across the state**

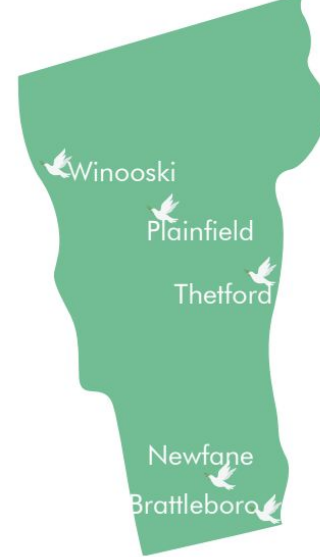

**40+ COMMUNITIES AROUND VERMONT HAVE ALREADY TAKEN THE PLEDGE**

## TOWNS & CITIES

Winooski, Brattleboro, Newfane, Thetford, Plainfield

## LABOR UNIONS

AFSCME 1674 Howard Center Union, UE 255 Local Hunger Mountain Co-op Union, Vermont Workers' Center + more

## COMMUNITIES

Free Her, The Peace and Justice Center, Migrant Justice, Education Justice Coalition of Vermont, Ascension Lutheran Church, Episcopal Diocese of Vermont + more

## BUSINESSES

Haymaker Buns, Marshfield Village Store, Otter Creek Yoga + more



# Advisory Question 101

## Burlington City Charter

Produce a petition containing the signatures of 5% of the registered voters in the city

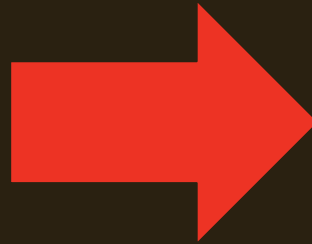

## Question on the Ballot

The advisory question is placed on the ballot for Burlington voters

# Burlington campaign history

## 2024 + 2025

2 years in a row, the VCPL collected the necessary signatures in Burlington to put AFC on the ballot

2 years in a row, **Democrats on the city council impeded the democratic process, killing the resolution in violation of free speech**

## Since then

5 Vermont towns have adopted AFC Vermont politicians, including VT Senate Democrats, Sen. Sanders, Sen. Welch, and Rep. Balint have called Israel's assault **genocide**

Burlington City Council passed a Free Speech Resolution in the wake of arrests of student leaders speaking in support of Palestine

# Recent actions by cities and towns against Israeli apartheid

## **Somerville, MA**

Nov 4, 2025

Ballot question to boycott and divest from businesses supporting Israeli apartheid passed with 55.7% of votes.

## **Burnaby, BC, Canada**

Aug 26, 2025

Passed resolution to endorse AFC and write to federal government demanding an arms embargo.

## **Iowa City, IA**

Aug 5, 2025

Passed resolution to boycott and divest from businesses supporting Israeli genocide and occupation.

## **St Louis, MO**

Nov 7, 2025

Passed resolution to divest city pensions from war and human rights violations by Israel.

# Let Voters Decide on Apartheid-Free Community

## Open Letter to the Burlington City Council

Dear Burlington City Council & Mayor Mulvaney-Stanak,

Democrats on the City Council blocked the AFC pledge advisory question from going to voters two years in a row, despite thousands of Burlington residents signing petitions to put the pledge on the ballot. In April 2025, the Council unanimously approved a resolution for protecting free speech on Palestine, and it is time to rectify the fact that our free speech rights have been repeatedly denied. There should be a democratic vote on adopting the pledge.

# Next Steps

## What this NPA can do:

- Vote on a resolution to call on City Council to uphold democratic norms and endorse the open letter to the Burlington City Council

## What you can do:

- **Sign** the open letter ([vermontcpl.org/btv](http://vermontcpl.org/btv))
- **Contact** city council democrats to demand the right to vote on AFC
- **Inform** your community about AFC and post on Front Porch Forum
- **Volunteer** with VCPL to support the Burlington campaign

**Ben Traverse**

btraverse@burlingtonvt.gov

(802) 357-2055

**Mark Barlow**

mbarlow@burlingtonvt.gov

(802) 549-4433

**Evan Litwin**

elitwin@burlingtonvt.gov

(802) 448-0802

**Sarah E Carpenter**

scarpenter@burlingtonvt.gov

(802) 658-0474

**Buddy Singh**

bsingh@burlingtonvt.gov

(802) 238-5131

**Becca Brown McKnight**

bbrownmcknight@burlingtonvt.gov

(802) 489-6439

**Allie Schachter**

aschachter@burlingtonvt.gov

(802) 448-4227



# Thank You!

**Questions? Contact us:**  
[apartheidfree@vermontcpl.org](mailto:apartheidfree@vermontcpl.org)

[Vermontcpl.org](http://Vermontcpl.org)

596 mm

# RAMALLAH HAS MORE ANNUAL RAINFALL THAN LONDON

619 mm



LONDON, UK

UK water resources



RAMALLAH, PALESTINE

West Bank Mountain Aquifer

Israel takes over 80% of the water from the mountain aquifer each year

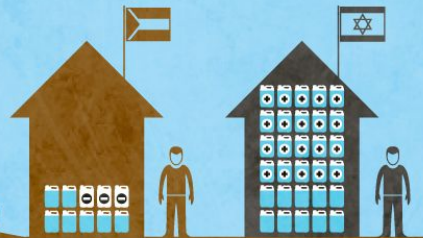

70 litres/day per Palestinian in West Bank

300 litres/day per Israeli including settlers



WHO RECOMMENDS 100 litres/day per person

- = 10 litres/day
- = 10 litres/day above WHO recommendation
- = 10 litres/day below WHO recommendation

## 1 APPROPRIATION OF WATER RESOURCES

Israeli authorities control all major water sources in the West Bank and determine how much water Palestinians can use.

## 2 CONTROL OF SUPPLY

Israeli authorities enforce annual quotas on the amount of water available to Palestinians.

## 3 OBSTRUCTION OF DEVELOPMENT

No new Palestinian wells approved by Israeli authorities in the most productive Western Aquifer since 1967.

## 4 DESTRUCTION OF INFRASTRUCTURE

In 2011, the Israeli military demolished 89 water-related structures, including 21 wells and 34 rainwater cisterns essential for agriculture and herding.

Aquifers inside Israel, Jordan river basin & desalinated water

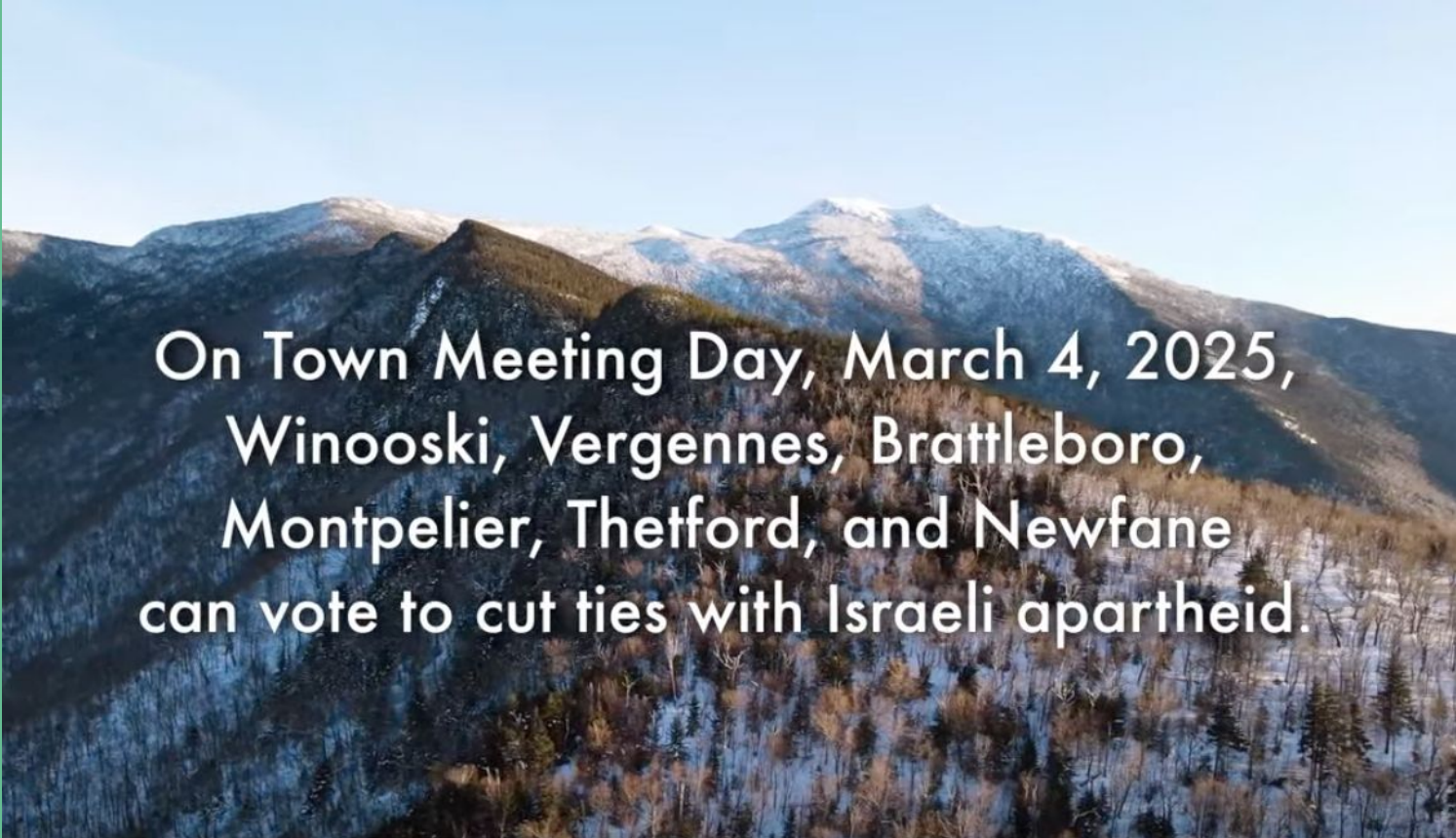

On Town Meeting Day, March 4, 2025,  
Winooski, Vergennes, Brattleboro,  
Montpelier, Thetford, and Newfane  
can vote to cut ties with Israeli apartheid.



# North Ave Redevelopment

Presented by Michael Chaucer from Haven Architecture LLC



# Introduction

**Michael Chaucer** is an Architect with Haven Architecture LLC. Michael works on residential projects throughout New England, with a focus on additions and new construction of single family homes and multifamily buildings. Michael is a graduate of the Boston Architectural College, the University of Vermont, and Burlington High School.

**Haven Architecture LLC** is a small architectural design firm with a team of five employees and an office on Battery Street in Burlington.



# Where is our project located?

Our project is located at 126 North Avenue, next door to the fire department and just a few houses North of Brian's Auto.



# What's there now?



The existing building is a rental duplex, built in the late 19th century. The foundation is failing, and decades of poor management has resulted in damage beyond repair.

# Why redevelop?

Burlington's housing shortage is no secret, and it's going to take an "all hands on deck" approach to fix it.

Our clients would like to do what they can to help ease the pressure on rental housing supply, using the small amount of property and resources at their disposal.

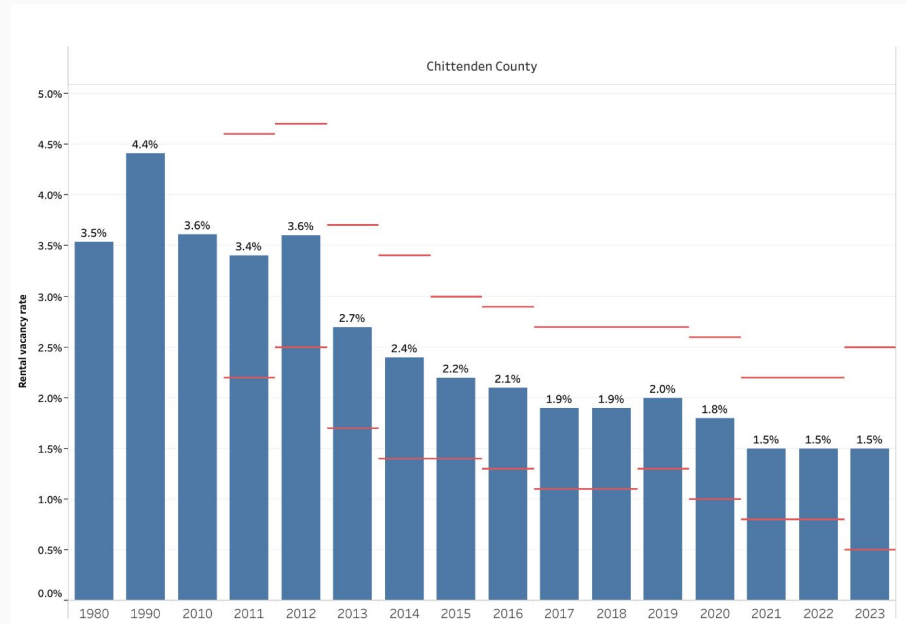

# What are our goals?

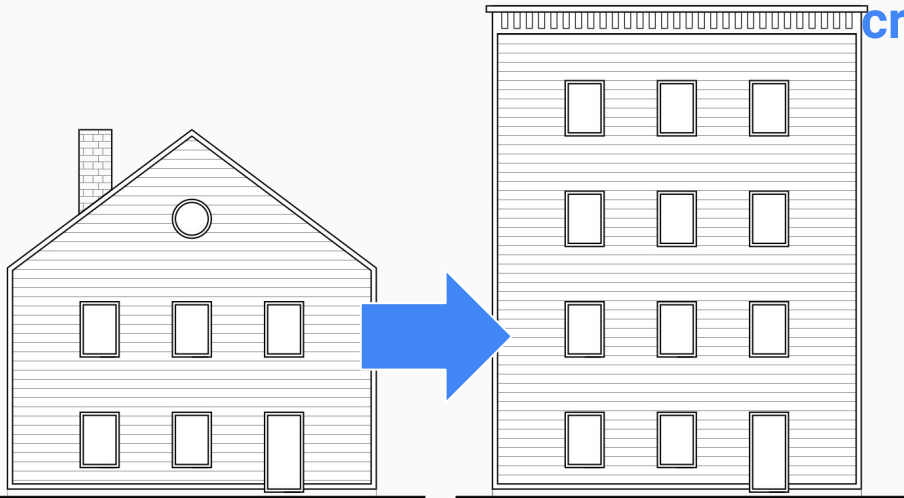

To utilize the new Neighborhood Code to create “missing middle” housing. The new building will include 16x highly efficient and affordable rental units.

The building will be all-electric, and will meet all of the latest energy efficiency standards. The rental rates will target middle-income affordability, and will provide a mix of 1- and 2-bedroom apartments.

# What will it look like?

We are taking inspiration from the Old North End buildings that we love and cherish. Our goal is to create a design that will fit seamlessly into the existing cultural fabric of our beloved neighborhood.

The new building will be four stories high, with traditional details and exterior treatments that reflect the building traditions of the Old North End.



# What about amenities?

This all-electric, high-efficiency building will be designed to be fully compliant with FHA accessibility standards, including wheelchair accessible elevator access. There will be indoor, secured bike parking for each resident, including E-bike charging stations. The building will be dog friendly, and will have a fenced in yard on site for our resident pups to play in, as well as a rooftop deck for neighborhood gatherings with a view.



# What is our timeline?

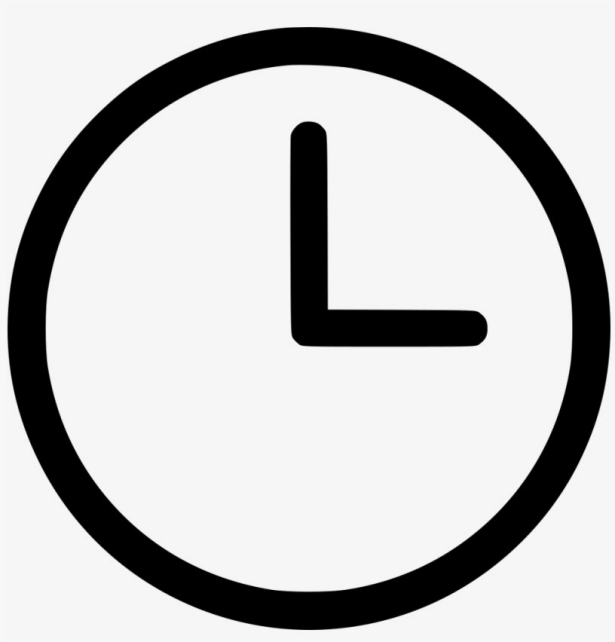

**We hope to begin construction in the Summer of 2026, and we expect construction to take 12-18 months. Our goal is to have the new homes available for rent by June 2028 or sooner!**

# Thank you!





# 134 ARCHIBALD STREET - BURLINGTON VERMONT CLIMATE ANALYSIS

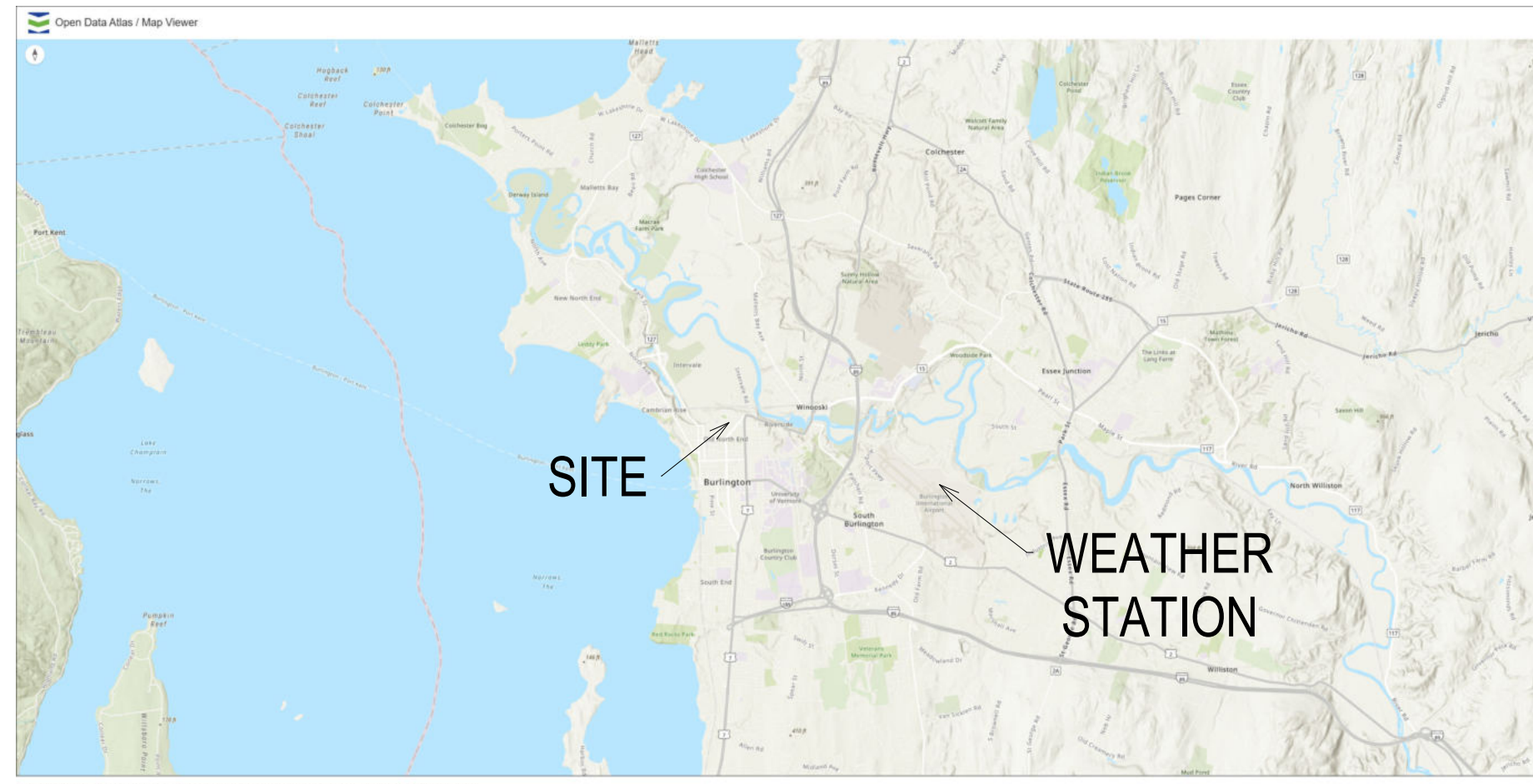

## BURLINGTON INTERNATIONAL AIRPORT, VT

Percent of winds blowing from the indicated direction  
Date range: 2000-01-01 through 2025-10-08

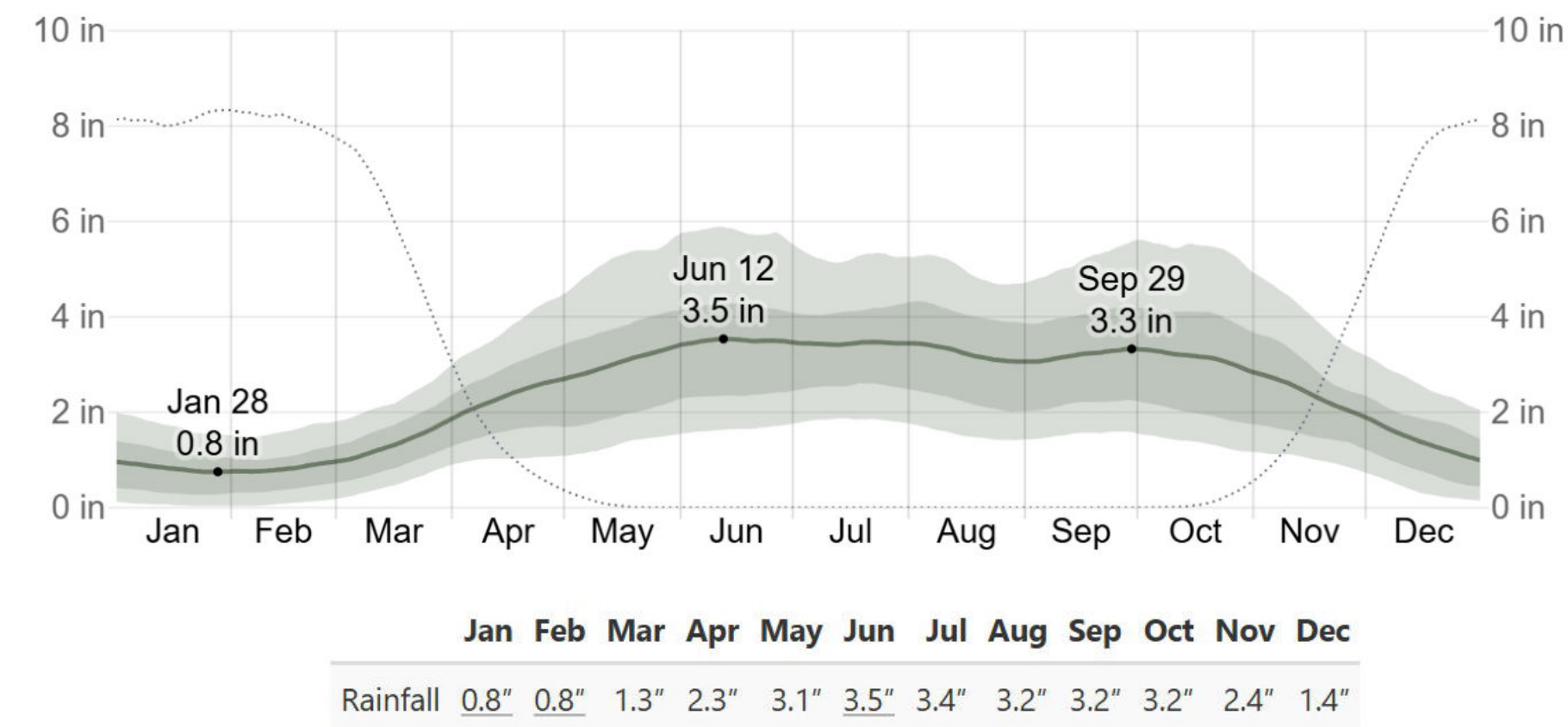
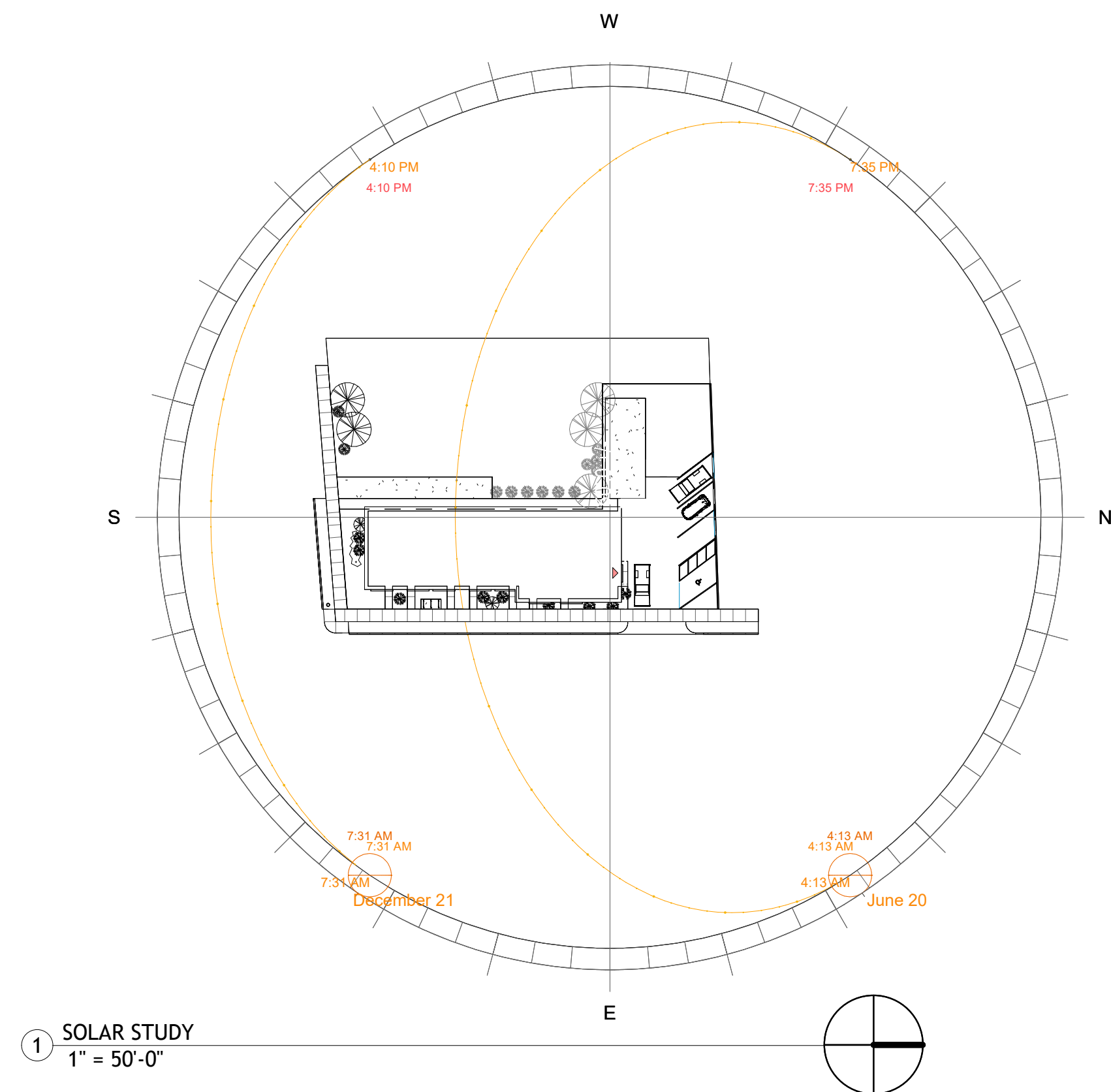
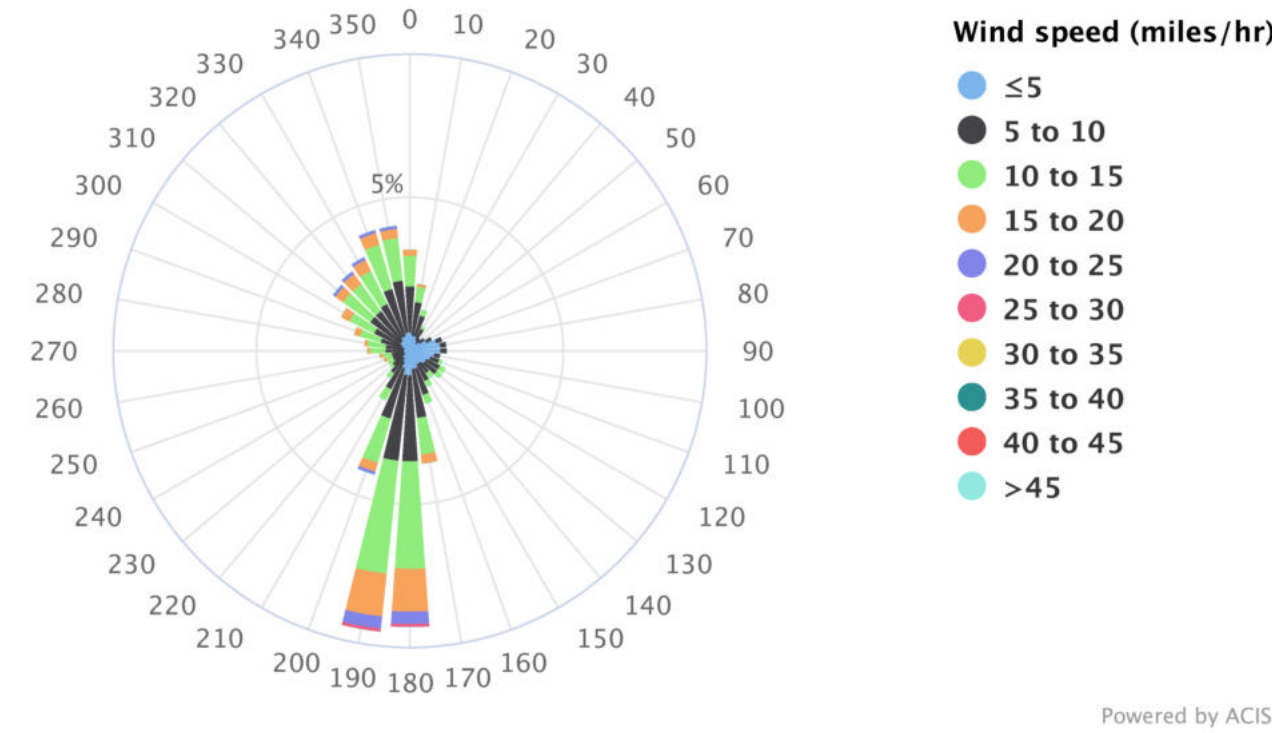

### DAILY PRECIPITATION

DAILY PRECIPITATION IN BURLINGTON, VERMONT IS MODERATE AND FAIRLY CONSISTENT YEAR-ROUND, WITH FREQUENT LIGHT RAIN OR SNOW RATHER THAN HEAVY DOWNPOURS. MOST DAYS SEE SOME CLOUD COVER OR DRIZZLE, BUT TRULY DRY STRETCHES ARE RELATIVELY SHORT.

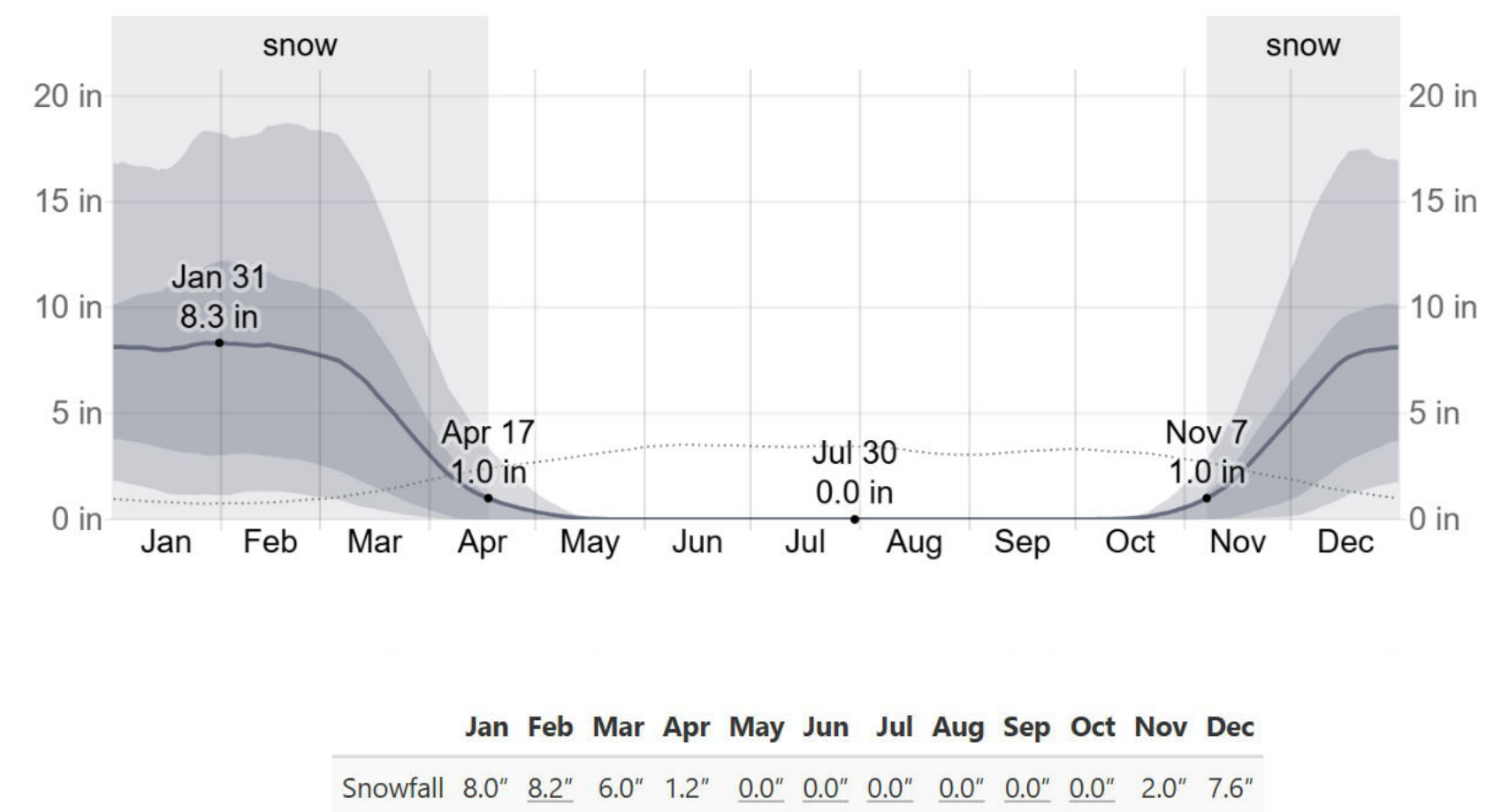

### AVERAGE SNOWFALL

BURLINGTON, VERMONT EXPERIENCES SUBSTANTIAL SNOWFALL FROM LATE NOVEMBER THROUGH MARCH, WITH THE HEAVIEST ACCUMULATION TYPICALLY OCCURRING IN JANUARY AND FEBRUARY. SNOW TENDS TO FALL STEADILY THROUGH THE SEASON, BUILDING A CONSISTENT WINTER SNOWPACK RATHER THAN ARRIVING IN SHORT BURSTS.

### HDD - HEATING DEGREE DAYS

FOR BURLINGTON, VERMONT, THE ANNUAL TOTAL IS ROUGHLY 5,400-5,600 HDD PER YEAR. THIS MEANS OVER THE COURSE OF THE YEAR, THE CUMULATIVE DEGREES BELOW 65 °F SUM TO ABOUT 5,400-5,600, REFLECTING THE CITY'S COLD CLIMATE AND LONG HEATING SEASON.

### CDD - COOLING DEGREE DAYS

FOR BURLINGTON, VERMONT, COOLING NEEDS ARE MINIMAL. THE CITY TYPICALLY ACCUMULATES ONLY ABOUT 50-60 CDD PER YEAR, MOSTLY IN JULY AND AUGUST DURING THE OCCASIONAL HOT SPELL. COMPARED TO HEATING, COOLING IS BARELY A FACTOR IN BURLINGTON'S CLIMATE.

Month	HDD (°F-day)	CDD (°F-day)
Jan	1,510	0
Feb	1,310	0
Mar	1,063	0
Apr	633	0
May	282	13
Jun	58	64
Jul	6	176
Aug	29	119
Sep	199	16
Oct	533	0
Nov	846	0
Dec	1,302	0
Annual	7,771	388

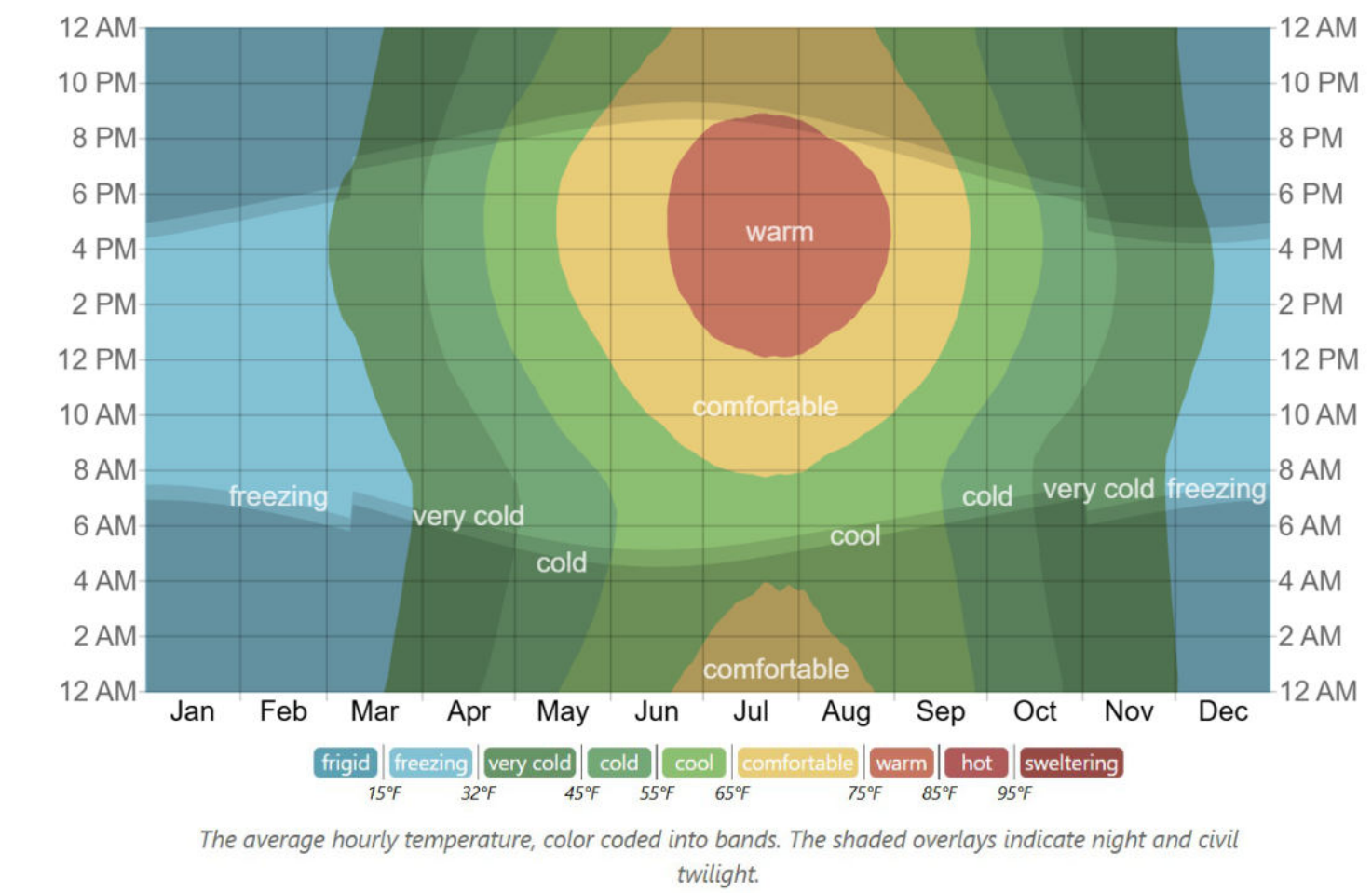

### AVERAGE DAILY TEMPS

AVERAGE DAILY TEMPERATURES IN BURLINGTON, VERMONT SWING WIDELY THROUGH THE YEAR, WITH COLD WINTERS OFTEN BELOW FREEZING AND WARM SUMMERS AVERAGING IN THE 70S-80S °F (21-29 °C). SPRING AND FALL SEE RAPID TRANSITIONS, CREATING NOTICEABLE DAY-TO-NIGHT AND SEASONAL TEMPERATURE SHIFTS.

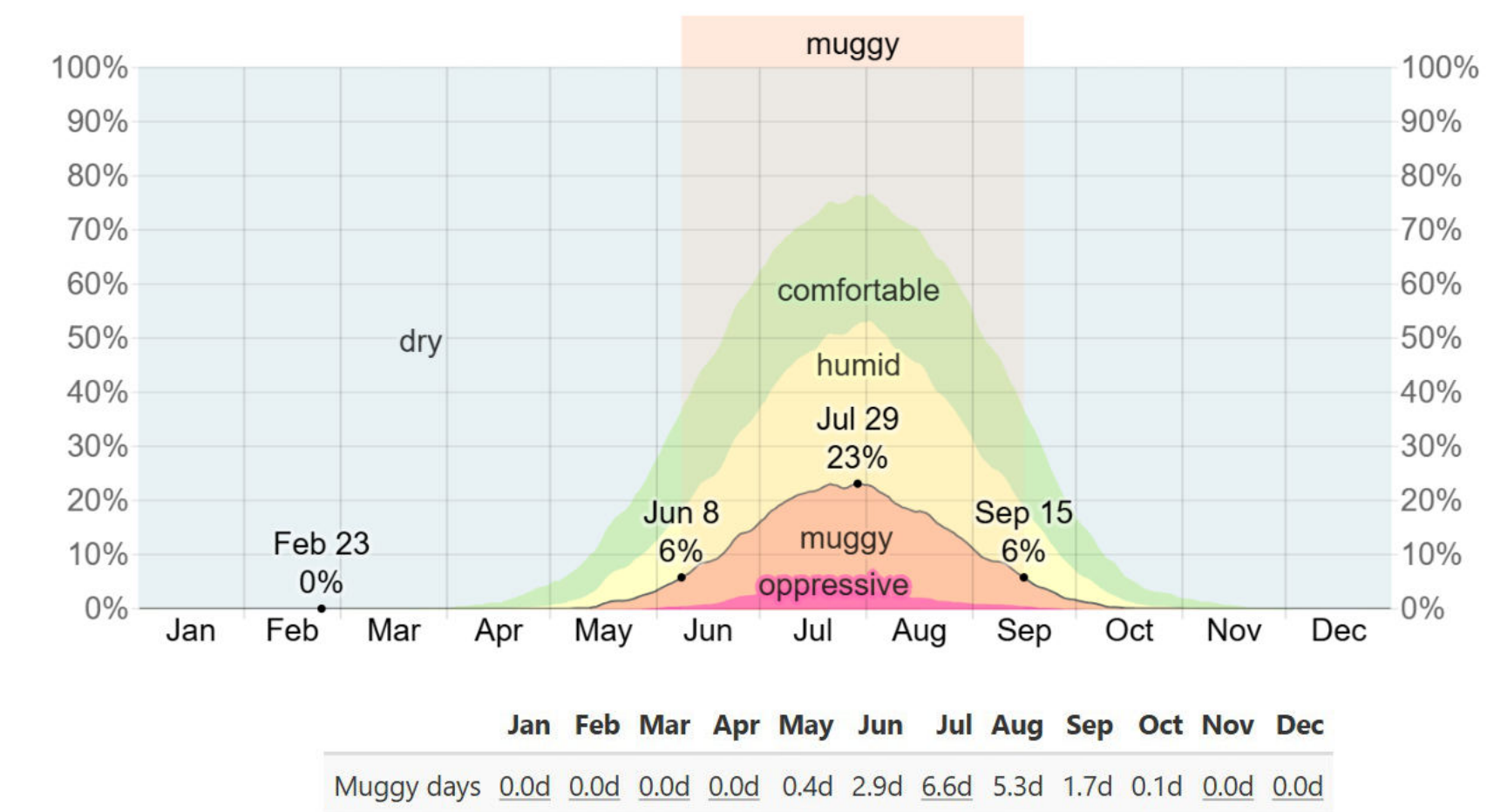

### HUMIDITY

HUMIDITY IN BURLINGTON, VERMONT VARIES WIDELY THROUGH THE YEAR. TYPICALLY LOW AND CRISP IN WINTER, THEN RISING THROUGH SPRING TO BECOME WARM AND OFTEN MUGGY IN JULY AND AUGUST. LATE SUMMER BRINGS THE MOST HUMID CONDITIONS, WHILE AUTUMN QUICKLY RETURNS TO DRIER, MORE COMFORTABLE AIR.

## DESIGN STRATEGIES

### SHADING + ORIENTATION

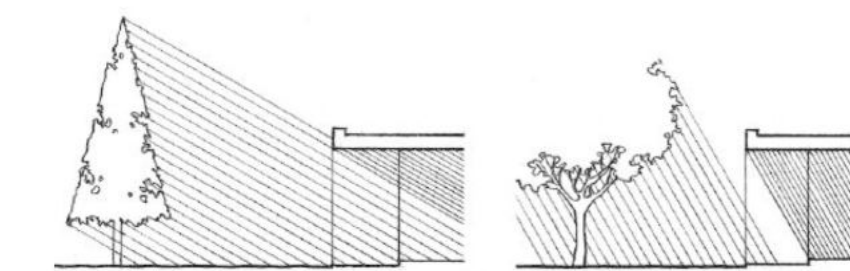

BUILDING ORIENTATION AND SHADING STRATEGIES MAXIMIZE ENERGY EFFICIENCY AND OCCUPANT COMFORT BY CONTROLLING SOLAR HEAT GAIN, REDUCING GLARE, AND LEVERAGING NATURAL LIGHT THROUGHOUT THE DAY.

### NATURAL VENTILATION

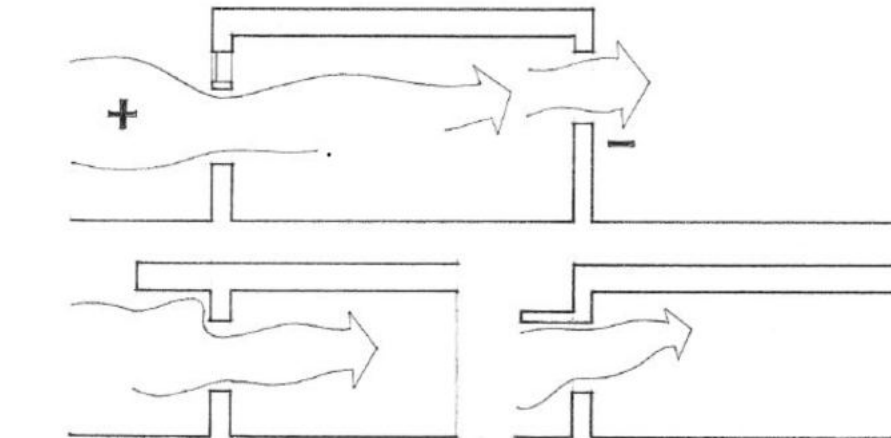

NATURAL VENTILATION HARNESSSES WIND AND BUOYANCY TO CIRCULATE FRESH AIR THROUGH A BUILDING, IMPROVING INDOOR AIR QUALITY, REDUCING RELIANCE ON MECHANICAL SYSTEMS, AND ENHANCING THERMAL COMFORT SUSTAINABLY.

### DAYLIGHTING CONTROLS

DAYLIGHTING CONTROLS, INCLUDING STRATEGIES LIKE AUTOMATED SHADING AND SUN SHELVES, OPTIMIZE NATURAL LIGHT USE, REDUCE ENERGY CONSUMPTION, AND ENHANCE OCCUPANT COMFORT BY BALANCING SUNLIGHT PENETRATION AND INTERIOR ILLUMINATION.

### SAFE MATERIAL SELECTION + SALVAGE MATERIALS

SAFE SALVAGING OF MATERIALS PROMOTES SUSTAINABILITY AND RESPONSIBLE BUILDING BY RECLAIMING AND REPURPOSING RESOURCES WHILE MINIMIZING ENVIRONMENTAL IMPACT AND HEALTH RISKS.

architect

**JRMA design studio**

architecture - planning - development  
www.jrmaestudiostudio.com

PROJECT MANAGER  
Mr. Michael Avanos  
172 Summit Circle  
Shelburne, Vermont 05482  
ph: 802-744-3613  
Email: Michael@JRMAestudiostudio.com

owner/client

civil

134 ARCHIBALD

architectural stamp

DISCLAIMER:  
THIS DRAWING AND ASSOCIATED DOCUMENTS ARE THE EXCLUSIVE PROPERTY OF JRMA DESIGN STUDIO, AND ARE NOT TO BE REPRODUCED OR COPIED IN WHOLE OR IN PART, EXCEPT AS REQUIRED FOR THE STATED PROJECT. THEY ARE ONLY TO BE USED FOR THIS PROJECT AND SITE SPECIFICALLY IDENTIFIED HEREIN AND ARE NOT TO BE USED ON ANY OTHER PROJECT WITHOUT WRITTEN CONSENT OF JRMA DESIGN STUDIO. SCALES AS NOTED ON THIS DRAWING ARE VALID ON THE ORIGINAL DRAWING ONLY. THE DIMENSIONS OF WHICH ARE 24 x 36 INCHES.

NO.	DESCRIP.	DATE
1	Revision 1	09.10.25
2	Revision 2	10.06.25
3	Zoning Permit	10.08.25

134 ARCHIBALD

CLIMATE ANALYSIS

Project number	2025 355
Date	2025 10 08
Drawn by	M.A
Checked by	M.A
Scale	1" = 50'-0"

A0.8

















EXTERIOR CLADDING - TREX

Trex® Cladding



RAINSCREENS THAT MAKE WOOD OBSOLETE

Trex® Cladding uses Signature® or Transcend® square-edge deck boards to complete a rainscreen system. Trex Transcend decking is a wood thermoplastic composite lumber (WTC) deck board with an integrated shell that covers the boards on the top surface and sides. The integrated shell consists of a proprietary surface formulation that produces a natural, wood-like grain pattern finish. The deck board is made from approximately 50 percent wood fiber and 50 percent polyethylene by weight and is an alternative to naturally durable hardwood lumber. Trex® deck boards are manufactured by a continuous extrusion process, are available in various colors and are code-compliant for type V-B structures under 40' in height.

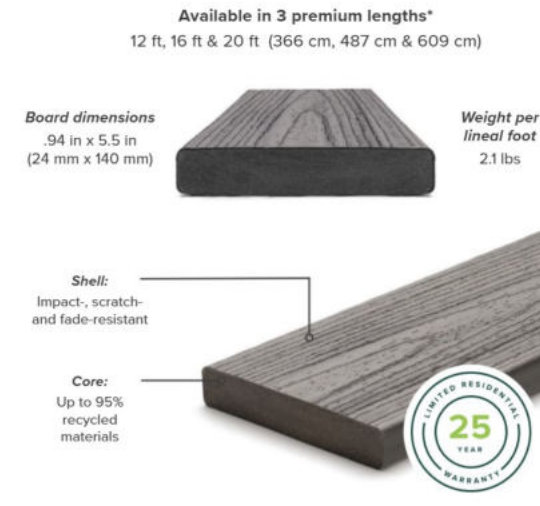

COLORS

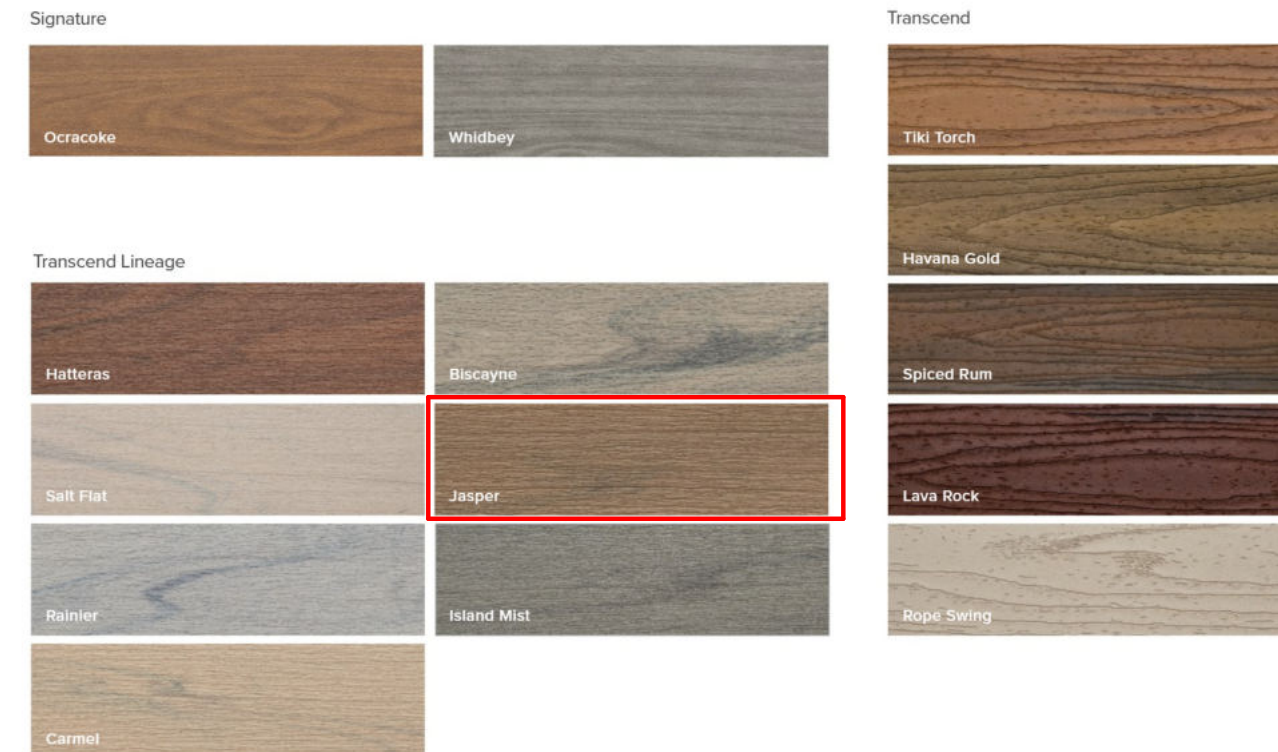

Trex® Cladding | Trex

PHYSICAL & MECHANICAL PROPERTIES

TEST	TEST METHOD	VALUE
Flame Spread	ASTM E 84	Class B
Thermal Expansion	ASTM D 1037	1.9 x 10 <sup>-5</sup> in/in/degree F
Moisture Absorption	ASTM D 1037	< 1%
Screw Withdrawal	ASTM D1761	558 lbs/in
Fungus Resistance	ASTM D1943	Rating = no decay
Termites Resistance	AWPAE-172	Rating = 9/6

TREX SIGNATURE OPEN-JOINT CLADDING ALLOWABLE DESIGN PRESSURES

MATERIAL	MINIMUM THICKNESS	SPACING	FASTENER DESCRIPTION	ALLOWABLE DESIGN PRESSURE
2x Wood Furring*	1.5"	24" o.c.	Two (2) #10 x 2" Starborn® Deckfast® Cap-Tor® w/ Composite Deck Screws or Two (2) #10 x 2" Starborn® Deckfast® Composite Deck Screws with Pro Plug® System	84 psf
2x Wood Furring*	1.5"	24" o.c.	Two (2) #10 x 1.75" Starborn® Deckfast® Fascia System Fascia Screws	38 psf
Steel Furring*	0.048"	24" o.c.	Two (2) #10 x 1.5/8" Starborn® Deckfast® Metal Composite Deck Screws (With Optional Pro Plug® System)	61 psf

TREX TRANSCEND AND TREX TRANSCEND LINEAGE OPEN-JOINT CLADDING ALLOWABLE DESIGN PRESSURES

MATERIAL	MINIMUM THICKNESS	SPACING	FASTENER DESCRIPTION	ALLOWABLE DESIGN PRESSURE
2x Wood Furring*	1.5"	24" o.c.	Two (2) #10 x 2" Starborn® Deckfast® Cap-Tor® w/ Composite Deck Screws or Two (2) #10 x 2" Starborn® Deckfast® Composite Deck Screws with Pro Plug® System	68 psf
2x Wood Furring*	1.5"	24" o.c.	Two (2) #10 x 1.75" Starborn® Deckfast® Fascia System Fascia Screws	73 psf
Steel Furring*	0.048"	24" o.c.	Two (2) #10 x 1.5/8" Starborn® Deckfast® Metal Composite Deck Screws (With Optional Pro Plug® System)	74 psf



EXTERIOR CLADDING - CORRUGATED METAL

PAC-CLAD  
PETERSEN  
A CALLESSE COMPANY

Color Guide

PAC-CLAD.COM

Performance and Availability

PAC-CLAD STANDARD COLORS	REFLECTIVITY	EMISSIVITY	3 YEAR EXPOSURE SRI	STEEL	ALUMINUM	25 IN. COIL
				24 GA.	22 GA.	0.010
AGED BRONZE	0.29	0.87	0.27	29	✓	✓
ALMOND	0.63	0.95	0.55	75	✓	✓
ANTIQUE BRONZE	0.28	0.86	N/A	27	✓	✓
ARNOVA BLUE*	0.25	0.86	0.23	24	✓	✓
BERKSHIRE BLUE*	0.29	0.86	0.27	29	✓	✓
BLACK (BLACK ALUMINUM)	0.05	0.95	0.64	0	✓	✓
BONE WHITE	0.90	0.86	0.64	95	✓	✓
BUCKSKIN	0.37	0.86	N/A	39	✓	✓
BUNGALOW	0.34	0.86	0.31	23	✓	✓
BURNISHED KATE	0.32	0.86	0.31	31	✓	✓
CARDINAL RED*	0.44	0.86	0.44	49	✓	✓
CHARCOAL	0.30	0.87	0.30	31	✓	✓
CITICARE	0.67	0.87	0.60	67	✓	✓
CLASSIC BRONZE*	0.27	0.87	N/A	27	✓	✓
COLONIAL RED	0.34	0.87	0.31	36	✓	✓
DARK BRONZE	0.27	0.86	0.29	26	✓	✓
EVERGREEN	0.90	0.86	0.26	4	✓	✓
FOREST GREEN	0.90	0.88	0.30	5	✓	✓
GRANITE*	0.32	0.86	0.33	33	✓	✓
GRAPHITE	0.66	0.86	0.28	24	✓	✓
HARTFORD GREEN	0.68	0.88	0.68	3	✓	✓
HEMLOCK GREEN	0.31	0.87	0.30	32	✓	✓
INNOVATE*	0.27	0.86	N/A	26	✓	✓
INDUSTRIAL BLUE	0.67	0.87	0.55	57	✓	✓
IRON ORE	0.27	0.87	N/A	27	✓	✓
MANSARD BROWN	0.31	0.87	0.31	32	✓	✓
ONYX (BLACK STEEL)	0.26	0.85	0.25	24	✓	✓
MEDIUM BRONZE	0.30	0.88	0.29	31	✓	✓
MIDNIGHT BRONZE	0.06	0.90	0.06	1	✓	✓
MILITARY BLUE	0.31	0.87	0.30	32	✓	✓
MIDNIGHT BLUE	0.27	0.87	0.27	27	✓	✓
PACIFIC BLUE (PACIFIC BLUE)	0.28	0.87	0.27	28	✓	✓
PATINA GREEN	0.33	0.86	0.32	34	✓	✓
PERLA WHITE	0.66	0.86	N/A	29	✓	✓
SANDSTONE	0.48	0.87	0.48	55	✓	✓
SIERRA TAN	0.38	0.85	0.31	40	✓	✓
SLATE GRAY	0.41	0.87	0.37	45	✓	✓
STONE WHITE	0.68	0.86	0.67	64	✓	✓
TEAL	0.31	0.87	0.32	32	✓	✓
TERRA COTTA	0.35	0.87	0.33	33	✓	✓
TRADITIONAL BLACK*	0.28	0.87	N/A	28	✓	✓
PAC-CLAD PREMIUM COLORS						
ANDIC CLEAR	0.51	0.81	0.31	60	✓	✓
CHAMPAGNE	0.40	0.78	0.49	40	✓	✓
COMPLEX PENNY	0.50	0.80	0.52	52	✓	✓
SILVER	0.47	0.82	0.46	52	✓	✓
SILVERSMITH	0.54	0.81	0.52	53	✓	✓
WEATHERED STEEL	0.26	0.86	N/A	25	✓	✓
WEATHERED ZINC	0.24	0.81	0.45	31	✓	✓
ZINC	0.33	0.84	0.38	33	✓	✓
CLEAR COAT ACRYLIC FINISH (NON-PVDF)						
GAVALUME PLUS	0.68	0.94	0.55	52	✓	✓

architect  
**JRMA design studio**  
 architecture - planning - development  
 www.jrmaestudio.com  
 PROJECT MANAGER  
 Mr. Michael Avanos  
 172 Summit Circle  
 Shelburne, Vermont 05482  
 ph. 802.734.3613  
 Email: Michael@JRMAestudio.com  
 owner/client

civil

134 ARCHIBALD

architectural stamp

DISCLAIMER:  
 THIS DRAWING AND ASSOCIATED DOCUMENTS ARE THE EXCLUSIVE PROPERTY OF JRMA DESIGN STUDIO, AND ARE NOT TO BE REPRODUCED OR COPIED IN WHOLE OR IN PART, EXCEPT AS REQUIRED FOR THE STATED PROJECT. THEY ARE ONLY TO BE USED FOR THIS PROJECT AND SITE SPECIFICALLY IDENTIFIED HEREIN AND ARE NOT TO BE USED ON ANY OTHER PROJECT WITHOUT WRITTEN CONSENT OF JRMA DESIGN STUDIO. SCALES AS NOTED ON THIS DRAWING ARE VALID ON THE ORIGINAL DRAWING ONLY. THE DIMENSIONS OF WHICH ARE 24 x 36 INCHES.

NO.	DESCRIP.	DATE
1	Revision 1	09.10.25
2	Revision 2	10.06.25
3	Zoning Permit	10.08.25

134 ARCHIBALD

EXTERIOR MATERIALS

Project number 2025 355  
 Date 2025 10 08  
 Drawn by C.R  
 Checked by M.A  
 Scale

A3.1



